

Latest Technology, Technological Challenges, and Market Trends for Frequency Generating and Timing Devices

■ Ajay K. Poddar and Ulrich L. Rohde

Recent downtrends in the economy have forced the entire electronic industry, including manufacturers of the frequency generating and timing devices, to be more competitive under the constraints of size, power consumption, and performance. These frequency generating and timing devices are used for a wide range of applications, varying from keeping track of real time, setting clock frequency for digital data transmission, frequency up-and-down conversion in RF transceivers, or clocking of logic circuits. In general, the specification of these devices depends on the application it is being used for. As a result, different frequency generating and timing devices technologies exist today, each technology suiting a specific need [1]–[16]. For industrial applications, two technologies are distinguished: mechanical and electrical oscillators [15]. In mechanical oscillators, the frequency selective element is a mechanical resonator like quartz, for high-end applications (e.g., wireless communication, real-time clocks, high-speed digital interfaces), or another type of bulk piezoelectric material, such as barium titanate or lead-zirconium titanate, for less demanding and cost-sensitive applications (e.g., digital audio, video, household appliances). In electrical oscillators, the frequency-selective element is integrated on the chip and comprises an R - C or a gm - C filter for low-end applications (e.g., clocking of logic), or an inductor-capacitor (LC) filter for more demanding applications (e.g., in frequency synthesizers for wireless communication and digital interfaces). Although the electrical performance of mechanical-oscillators cannot be met by electrical oscillators, conventional mechanical oscillators have some important drawbacks that prevent their use in some applications. Conventional mechanical resonators are relatively bulky, cannot be integrated on a CMOS die, and are difficult to integrate into the same package that contains the CMOS die without increasing the manufacturing complexity and cost. Therefore, mechanical resonators have to interface with other circuit components on board level and hence they form a bottleneck for the ultimate miniaturization of the electronic system. In contrast, the use of electrical oscillators is limited to applications where accuracy and noise specifica-

tion is relaxed. Their stability and phase noise can be improved by locking them to mechanical oscillators using a phase-locked loop (PLL) [16].

The growing production of watches, mobile phones, Bluetooth and wireless LAN (WLAN) products, liquid crystal displays (LCDs), PCs, and various automotive systems continue to drive strong demand for nonsilicon resonator [quartz, ceramic, and surface acoustic wave (SAW)]-based oscillators and voltage-controlled oscillators (VCOs). The nonsilicon resonator sector faces threats from CMOS and silicon MEMS resonator types. CMOS resonators are a breakthrough technology that can replace ceramic- and SAW resonator-based frequency-controlled circuits that operate at 500 MHz and above in most electronic systems because they offer significant advantages in total manufacturing capacity, and lower cost.

CMOS Resonators are just beginning their learning curve, and are expected to follow Moore's law on future size and cost reduction capabilities. CMOS resonators also offer a path towards IC integration, which is not possible with non-CMOS products.

Another big player is silicon MEMS: the MEMS resonator-based oscillators will target applications where the size, degree of integration, and resistance to electromagnetic interference are key factors. When a quartz crystal is fabricated, it is designed to resonate at a single frequency throughout its lifetime. Changing the function of the quartz clock from one that operates a cell phone to one that runs a high-definition television, for example, requires fabricating an entirely different batch of crystals operating at different frequencies. The high levels of miniaturization achievable by MEMS technology allows a cost-effective solution to having high-Q resonators, operating at different frequencies. The downside to this is MEMS are capital-intensive, hampering the suppliers from using relatively new technology, that gives the desired ultra low phase noise performance and eliminates the reliability issues.

Cost dynamics play an important role, especially for consumer frequency-generating devices. There is noticeable marketing push for an entire silicon MEMS resonator-based oscillator to displace the quartz crystal technology and to open up the prospect of clock source integration. MEMS oscillators appear well suited to high-vibration environments, to noncritically timed applications, and to applications where the signal-to-noise ratio are not critical. MEMS devices, unlike ICs, contain moving fragile parts that must be properly packaged and meet the requirements such as protection against handling,

Ajay K. Poddar is with Synergy Microwave Corp., New Jersey, and Ulrich L. Rohde is with the University of Munich, Germany.

Digital Object Identifier 10.1109/MMM.2012.2206952
Date of publication: 13 September 2012

shielding against electromagnetic fields, near-hermetic cavity seal, low temperature process, good heat-exchange, minimal thermal stress, and RF electrical feed through before it becomes commercial viable alternatives.

Dynamics of Time and Timing Devices

A continuous effort has been put into making electronic devices to measure time and control the frequency with ever increasing accuracy, smaller size, lower power consumption, and lower cost. The accuracy of frequency-generating devices for timing solutions depends on such parameters like phase noise, thermal drift, harmonics, tuning sensitivity, stability, and aging.

Crystals, SAW, ceramic resonator oscillators, RC oscillators, and silicon resonator oscillators are five main types of clock sources for use with a microcontroller. The optimal clock source for an application depends on many factors including cost, accuracy, and environmental parameters. From simple RC oscillators accurate to about 30,000 ppm, to atomic clocks with accuracies of greater than 0.001 ppb, there are clocking options to meet the needs of every application. For years, bulk acoustic wave (BAW) crystal oscillators satisfied the majority of requirements, providing accuracies in the 10-ppm range. Less-accurate options, such as SAW oscillators, ceramic resonator oscillators, and IC oscillators, each have advantages to meet specific needs. While many characteristics define the performance of the frequency generating devices, the phase noise is the important parameter for given discrete and integrated solutions.

Quartz-based devices have long been a standard by which most other timing devices have been compared. The history of quartz as a stable, controllable, high-quality material for frequency selective and clocking devices is universally recognized, and frequency versus temperature response, aging, and jitter and phase noise characteristics are well chronicled in the industry.

This study reports the high Q-factor resonators for the application of frequency-controlled circuits and timing devices and their market dynamics

for the application in modern electronic and communication systems. Resonators fall into the two categories: discrete and integrated, and the next section will cover each individually.

High Q-Factor Resonators

Discrete Resonators

A typical discrete version is a nonsilicon resonator, such as quartz, ceramic, or SAW, that can be found

Designers and manufacturers now have new options for applications such as in telecommunication and data networks as well as consumer products.

in frequency-controlled circuits and timing devices. Frequency generators are integral components of all the electronic systems that need to communicate data. Current frequency control and timing products in the market are based on the use of resonators made of nonsilicon materials and devices. One good portable example is the cellphone handset. In the earlier models, a typical GSM handset had four different sets of piezoelectric frequency control components:

- 1) RF SAW filter (~900 MHz to 2 GHz using piezoelectric lithium tantalate or lithium niobate) for filtering signals between the antenna and the transceiver chipset
- 2) IF SAW filter (~50 to 400 MHz using mainly quartz) if super heterodyne down conversion is used
- 3) TCXO (temperature-compensated crystal oscillator, 13/26 MHz using quartz crystal) as clock

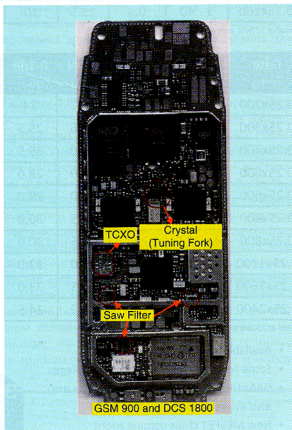

Figure 1. Piezoelectric components in a typical dual-band GSM handset (GSM900 and DCS1800) [1].

reference in the transceiver synthesizer for channelization

- 4) a tuning fork (32.768 KHz using quartz crystal) for standby clocking in the baseband section ($2^{15} = 32768$).

Later on, the successful development of direct conversion technology obsoleted the IF SAW filter in many GSM handsets (Figure 1). The GSM transceiver chipsets with an on-chip digitally compensated crystal oscillator (DCXO) circuit began to appear [1], hence the TCXOs are no longer needed to pair with these transceiver chipsets. An off-chip quartz crystal is still needed (Figure 2): Table 1 describes the typical crystal- and SAW-based products for frequency control circuits and timing devices.

Designers and manufacturers now have new options for applications such as in telecommunication and data networks as well as consumer products, thanks to some recent developments in oscillator technology. These include configurable oscillator technology, making the delivery of oscillators and voltage-controlled crystal oscillators (VCXO) more timely and affordable than ever before. Hence, these oscillators still remain extremely competitive with their MEMS and SAW oscillator counterparts in terms of cost, performance, and delivery times. The configurable crystal oscillator technology stands strong in its ability to deliver its technical and business advantages across a frequency range of 750 kHz to 1.35 GHz with low jitter (less than 1ps) and phase noise characteristics better than those of MEMS oscillators. Designers of subscriber applications

TABLE 1. Crystal- and SAW-based products [1].

Crystal-Based (MHz ~ 200 MHz)	SAW-Based (< 50 MHz ~ 2.5 GHz)
Passives	
Tuning fork and AT-cut Crystal	SAWR
MCF	SAWF
Oscillators-	
CXO (=OXO=SPXO)	CSO
PCXO (programmable)	PCSO
VCXO (voltage-controlled)	VCXO
VCXO (temperature-compensated)	TCSO
OCXO (oven-controlled)	OCXO
Timing modules-	
CDR (clock data recovery)	CDR (clock data recovery)
CS (clock smoother)	CS (clock smoother)
FX (frequency translator)	FX (frequency translator)
STM (synchronous timing module)	STM (synchronous timing module)

such as wireless WiMAX or WiBro data networks find this combination particularly attractive.

This customizable technology also enables crystal oscillators to find applications as diverse as the clock source in 10G Ethernet, optical networks, storage-area networks (SANs), FPGAs, ADSL, and various other areas. Table 1 describes the application of the quartz crystal and its high-frequency version, the SAW device, as an electronic toy to a complex synchronous timing module (STM) for the backbone clocking of the sophisticated telecom networks. The demand for quartz crystals and crystal oscillators has been increasing steadily between 4 to 10% annually since the "dot-com" market collapse in the 2000-2001, but was restricted to the frequency below 200 MHz. Recent downtrends in telecom market caused 50 to 80% drop in revenues, as business strategies have been to service mainly the telecom giants with mid- to high-end quartz crystals and crystal oscillators (HFF inverted mesa crystal, XO, VCXO/VCSO, TCXO, OCXO, and timing module). The telecom quartz crystal and crystal oscillator market is showing signs of recovery, and in the meantime, many more crystal oscillator suppliers are investing in developing mid- to high-end crystals and crystal oscillators to prepare for the telecom market return. Suppliers who suffered during the downturn will be glad to see the market return but they will find more competitors out there and the telecom customers will demand lower prices.

Despite quartz being the material of choice for high performance TCXOs, there are several drawbacks and limitations to this technology. The first difficulty is related to the attachment of miniaturized quartz plates to the ceramic package with solder balls. Precise control during the assembly is crucial to prevent spurious modes as well as packaging related stresses from affecting the temperature stability of the quartz resonator. Secondly, the

quartz is fragile material. The presence of handset manufacturers moving towards smaller packages has led to the use of smaller quartz plates, and as a consequence, thinner plate is determined by the thickness of the quartz plate and the mode being used, the absolute manufacturing tolerances become more challenging for thinner plates.

A long-term research activity to produce a low cost, high frequency fundamental crystal resonator in Giga-hertz band resulted in the development of the inverted Mesa-type crystal resonators (Figure 3) [3]. As shown in Figure 3, the centre portion of the Mesa quartz

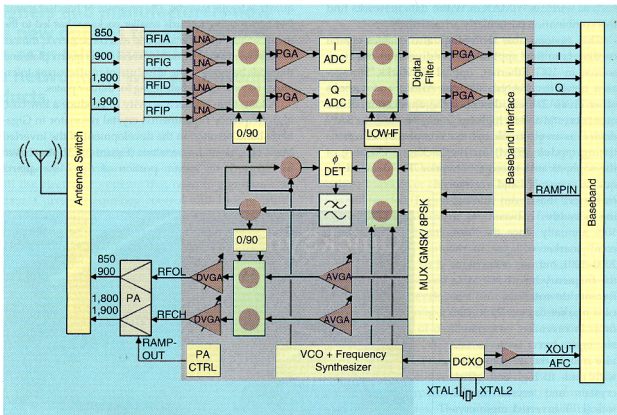

Figure 2. GSM transceiver chipset with on-chip DCXO [2].

resonator is thinner than the outer ring so that centre ring vibrates at higher frequency without breaking. The outer thicker ring of the quartz forms a strong frame structure around the thin fragile-etched central resonating layout, which is etched to known thickness corresponding to the operating frequency. The strong outer ring enables ease of handling. This technique allows the manufacture of very thin quartz crystal resonators, but it still needs lot of effort to manufacture and process, therefore is not an economically viable solution to date.

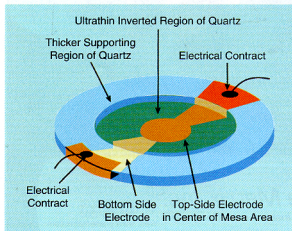

Figure 3. A typical inverted high-frequency Mesa quartz resonator [3].

Integrated Resonators

As ICs continue to shrink, these silicon resonators, unfortunately, do not follow the same Moore's law for miniaturization. Thus, they ultimately restrict the ability to reduce the overall IC system's size and cost. In addition to this, quartz crystal, ceramic, and SAW devices are produced through a labor-intensive process, wherein each device has to be finely tuned to achieve the desired resonance frequency characteristics.

The idea of abandoning nonsilicon resonators (quartz, ceramic, and SAW) for an integrated silicon solution is not new. RF system designers stress the need for higher levels of integration in RF function blocks. Such a modular approach provides amenable RF and digital interfaces, speeds the time to market, and simplifies system-level integrations. Commercially available nonsilicon resonator-based oscillators do not provide the low-cost and power-efficient solutions in the compact size to address these needs, whereas the integrated silicon solutions are cost effective and compact in size, but phase noise performance and reliability are currently not good enough to displace the nonsilicon technology.

For the most part the quality of these silicon systems has not matched that of quartz. The risk factors associated with the integrated silicon solution are too high for ultra-stable and ultra-low phase noise frequency-generating circuits and timing devices, since

the optimization (stability, jitter, thermal drift, reliability) and resulting changes during the IC design phase can be expensive and time consuming.

This study examines the pros and cons of non-silicon resonators (quartz, ceramic, and SAW) and describes the possible alternative solutions like using MEMS and TAI resonators that feature cost-effective, integrable and quick development.

Examples of Frequency Generation Circuits

Crystal Oscillator Circuits

Due to their high Q and temperature-stable properties, quartz crystal oscillators have been important clock sources in commercial, industrial, and military products for many years. The quartz crystal and crystal oscillator industry has made major progress in miniaturization, performance enhancement, and cost reduction in the past ten years. The unique fabrication and encapsulation requirements render quartz crystals and crystal oscillators difficult or almost impossible to integrate onto the silicon-based IC platforms.

For many years the fixed-frequency crystal oscillator market needs were mainly for CMOS output (single end) and less than 70 MHz products. For these low frequencies, a third-overtone (OT) quartz crystal was considered easy to process. The thrust was to reduce the size and to lower the supply voltage of crystal oscillators. The recent strong growth in the networking and storage market boosted the demand for differential output (LVPECL and LVDS) oscillators up to 160 MHz. Products are now available in 7×5 and 5×3.2 mm [2] package platforms from many suppliers. There are three groups of products with different performances. The first group consists of the pairing of either a HFF (high frequency fundamental) quartz crystal, a third-OT quartz crystal, or a fundamental SAW resonator with a traditional feedback loop oscillator IC. The second group pairs a low frequency quartz crystal (20 to 35 MHz) with a simple divider phase-lock loop (PLL) IC. The third group consists of the pairing of a third OT quartz crystal with a higher level PLL IC, e.g., a third OT quartz crystal with an AFM (analog frequency multiplier) IC, a third OT

Due to their high Q and temperature-stable properties, quartz crystal oscillators have been important clock sources in commercial, industrial, and military products for many years.

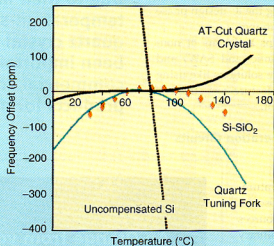

(a)

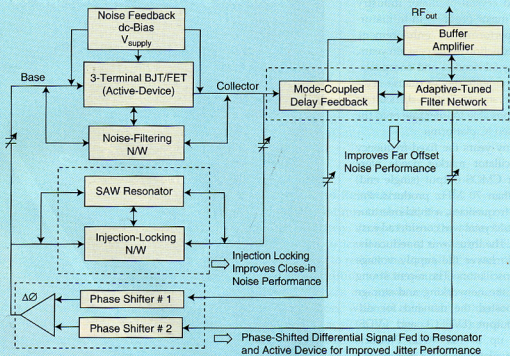

(b)

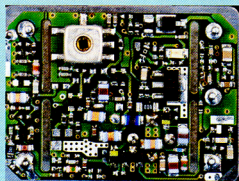

(c)

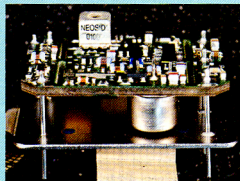

(d)

Figure 4. (a) Frequency shift as a function of frequency for AT-cut quartz, tuning fork quartz, Si, and oxidized silicon resonator, (b) schematic of 100 MHz crystal oscillator circuit, (c) measured phase noise plots, and (d) measured phase noise plot of a 125 MHz ovenized controlled crystal oscillator (OCXO) using mode-feedback technology.

quartz crystal with a fully programmable DSPLL oscillator IC [2]–[4]. The above solutions offer less than 1 ps rms phase jitter (12 KHz to 20 MHz). Except for the SAW solution, the above solutions offer the frequency-temperature property similar to the typical AT-cut quartz crystal cubic frequency-temperature property. The solutions provide the options of ± 100 , 50 and 25 ppm f-T performance. Crystal oscillators using additional temperature compensation, also referred to as temperature compensated crystal oscillator (TCXO), are able to achieve typical frequency stabilities of ± 2.5 ppm/year at room temperature, typical phase noise of -138 dBc/Hz at 1 kHz offset and power consumption as low as 1.5 mA. The smallest commercially available TCXOs are currently available with dimensions of $2.0 \times 1.6 \times 0.8$ mm [3], [5]. Figure 4(a) shows the typical frequency shift [15], schematic and phase noise plot of differential coupled 100 MHz crystal oscillator (XO). As shown in Figure 4(b), the mode-feedback technique minimizes the phase noise by 10–15 dB, resulting in a cost-effective solution. The typical measured phase noise is -139 dBc/Hz at 100 Hz offset from the carrier, which is reasonably low phase noise solution for the class of inexpensive crystal resonator oscillators. Latest developments like the injection locking can improve the phase noise performance further below as shown in Figure 4(d).

Ceramic Resonator Oscillator

Ceramic CROs (coaxial resonator oscillators) are widely used in wireless applications, since the technology features low phase noise at fixed frequencies through about 4000 MHz. Ceramic resonator based oscillators are also known for high quality factor (Q), and low phase noise performers. Typically, a ceramic resonator comprises a dielectric material formed as a rectangular prism with a coaxial hole running lengthwise through the prism and an electrical connector connected to one end. The outer and inner surfaces of the prism, with the exception of the end connected to the electrical connector and possibly the opposite end, are coated with a metal such as copper or silver. A device formed in this manner forms a resonant RF circuit, including capacitance, inductance, and loss resistance that oscillates, if loss resistance is compensated, in the transverse electromagnetic (TEM) mode. The benefits gained with this design include high Q, and low phase noise.

CROs have several disadvantages, such as: limited temperature range, limited tuning range (limits the amount of correction that can be added to compensate for the tolerances of other components in the circuit), and sensitivity to phase hits (due to expanding and contracting at different rates with variation of the temperature for outer metallic body of the coaxial ceramic resonator and other components of the oscillator circuit). Care must be taken by the designer, like using a digitally implemented CRO to overcome the above problems, otherwise, large phase hits can unlock many communication links if not absorbed. In addition, since the design of new CROs is much like that of an integrated circuit (IC), development of an oscillator with a non-standard frequency requires nonrecurring engineering (NRE) costs, in addition to the cost of the oscillators.

Figure 5 shows the schematic, layout and phase noise plots of a 1 GHz CRO, the typical phase noise at 10 kHz offset is -125 dBc/Hz. CROs are generally used for less accurate applications [6]. Initial accuracy (calibration) of these devices ranges from $\pm 0.05\%$ to $\pm 1.0\%$. Temperature stability is approximately 15 ppm/ $^{\circ}$ C for ceramic resonators. Aging is in the range of $\pm 0.5\%/10$ years. These devices have much lower Q than quartz crystals and also seem to be more prone to spurious modes of operation.

SAW Oscillator

SAW devices are generally used in frequency ranges above that of the BAW (bulk acoustic wave) crystal such as the AT cut. All of the previously discussed crystals have been BAW crystals and thus the bulk of the quartz is involved in the area of excitation. The SAW involves only the surface of the substrate used. The frequency is set by the distance between the electrode "fingers" [Figure 6(a)]. Quartz, LiTaO₃, and LiNbO₃ are common substrates for such devices. Initial accuracy is dependent on the accuracy of the printing of the "fingers."

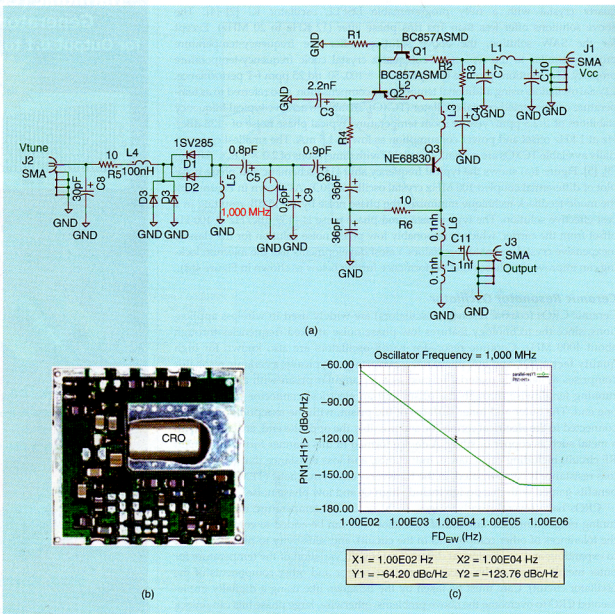

Figure 5. (a) Typical schematic of 1 GHz CRO [6]. (b) Layout of 1 GHz CRO [6]. (c) Simulated and phase noise plot of 1GHz CRO.

Initial accuracy can be in the ± 50 to 200 ppm range. The approximate temperature constant of quartz is $0.03 \text{ ppm}/^\circ\text{C}^2$ and $-20 \text{ ppm}/^\circ\text{C}^2$ for LiTaO₃. Upper frequencies of 3.5 GHz are currently obtainable. Currently, SAW-resonator based oscillators are used for high frequency signal sources, which have cost, availability, and frequency stability issues.

The shift to multiband 3G phones has increased the demand of SAW filters per handset. This implies a substantial increase in the filtering functions, thereby increasing the filter count in handsets. Combinations of multiband, multimode models are expected to use increasing number of SAWs. As more phones operate on multiple bands, manufacturers are expected to require more SAW filters, thereby increasing the overall SAW filter market size. The SAW devices find

applications in the following product segments: SAW filters, SAW resonators and SAW oscillators.

SAW oscillators are widely used in wireless applications, since the technology features very low phase noise at fixed frequencies through about 3 GHz. SAW resonator oscillators are also known for their low microphonic noise (tolerance to vibration), high quality factor (Q), and low jitter. SAW oscillators have several disadvantages, including a limited operating temperature range and limited tuning range (limits the amount of correction that can be made to compensate for the tolerances of other components in the oscillator circuitry). In addition, since the design of a new SAW oscillator is much like that of an integrated circuit, development of an oscillator with a nonstandard frequency requires NRE costs, in addition to the cost of the oscillator.

Recent improvements in SAW VCO technology show improved thermal-drift and phase-noise performance compared to other SAW oscillators at comparable frequencies with footprints as small as 0.5 by 0.5 inches.

Figure 6(b) and (c) shows a typical schematic and phase noise plots of the 1 GHz SAW oscillators, the typical phase noise at 10 kHz offset is -153 dBc/Hz. These new SAW VCO technologies using mode-feedback and injection locking mechanism can be readily modified for use in the 300–5000 MHz range, offer significant promise in terms of performance, price, and product delivery to satisfy both the technical and business needs of designers and buyers. The need for accurate, affordable, low-noise and stable performance never changes even when oscillators are used at their specific frequency or tuned to higher frequencies using multipliers or PLLs.

Integrated Resonators

Integrated resonators are typically fabricated using Silicon and CMOS MEMS fabrication technology. Figure 7 shows the typical matrix of MEMS resonator and their mode shapes [12]. As shown in Figure 7, flexural mode includes folded beam, clamped-clamped beam, free-free beam, and ring resonators. Typically, flexural mode resonators cover the frequency less than 100 MHz due to the limit of resonator's mechanical stiffness. Figure 8 shows a graph showing the frequency-Q product, a common figure of merit for resonators, increased exponentially over recent years [13].

As the handset market continues to grow, developing MEMS-based RF components such as switches, filters, resonators, VCO, etc. seems to be the logical route toward integration (Figure 9). MEMS-based oscillators allow for higher levels of system integration at low cost, compared to established quartz technology. These advantages are a direct result of the material compatibility with standard CMOS production and the batch type of processing of both the resonator and its package. In particular, surface micro-machined on-wafer thin film packages result in a very small form factor, low cost package that is in many cases compatible with existing CMOS infrastructure [15].

The relatively recent introduction of MEMS-based oscillators has been accompanied by claims that this technology would finally replace quartz by providing lower costs, shorter design and production cycle times, excellent shock and vibration performance, and superior signal quality. In particular, as the integration difficulties of the quartz crystal with the oscillator IC scale inversely with the size of the package, the use of MEMS resonators would promote a monolithic solution of MEMS and IC. Despite these claims, few studies have been available to help understand the performance characteristics of MEMS oscillators. This investigation seeks to provide a direct comparison of MEMS oscillators with traditional quartz-resonator-based oscillators.

Commercially available MEMS oscillator solutions targeting low-end timing solutions still struggle for general acceptance as a replacement of TCXO because MEMS oscillator as a TCXO alternative, to date fails to achieve the combination of: (1) temperature stability, (2) low phase noise and (3) frequency accuracy.

Figure 10 shows the typical 67.5 MHz quartz crystal and MEMS oscillator for comparative analysis [12]. Figure 11 shows the typical MEMS enables RF signals source [6].

Promise of CMOS MEMS resonators has been immense for a long time. Finally, technology is commercially viable, and being rolled out as we speak. These MEMS oscillators provide opportunities to change traditional timing devices that people are inured to for decades. With the advantages of low cost, low power, high reliability, and integration, MEMS oscillators will grow and evolve over time. Quartz Crystal technology is very important and relevant, and will continue to have its unique share of the market, though over time this share may probably be on the decline.

The recent advancements in MEMS and packaging technologies have triggered serious efforts to replace crystal-based oscillators with promises of smaller size and lower prices. Nonetheless, non-MEMS based approaches relying on integrated LC-tanks have emerged and are claiming performances appealing to

consumer applications. Both approaches need to innovatively tackle two issues with minimum impact on phase noise and jitter: Frequency stability across temperature and frequency programmability.

Fueled by rapid growth in the IT industry, the global market share of crystal oscillators reached over \$ 4 billion in 2011. Feeling the pinch of the global recession, consumers are now more conservative when it comes to spending on electronic products. For 2012, despite the negative impact of the worldwide economic crisis, analysts are optimistic that the crystal component sector will register a healthy growth of over 10 percent.

Various types of MEMS resonators have already been in development for more than 40 years. The nascent technology, nevertheless, makes too expensive

to compete with conventional quartz crystals. Due to their material characteristics, silicon-based MEMS oscillators have to use a temperature compensated circuit to tune the resonance frequency back to an acceptable scale. The vibration mechanism of the silicon MEMS resonator is still not very stable in the short term and that makes the MEMS oscillator unable to achieve market acceptance at this time.

Until now, MEMS oscillators had taken only limited advantage of MEMS integration. The market is obvious when looking at existing timing solutions—currently consisting of a large socket on which a PLL ASIC is placed as a discrete, bulky quartz sensor. MEMS oscillators offer the same functionality as a one-chip solution and now compete directly with products which have

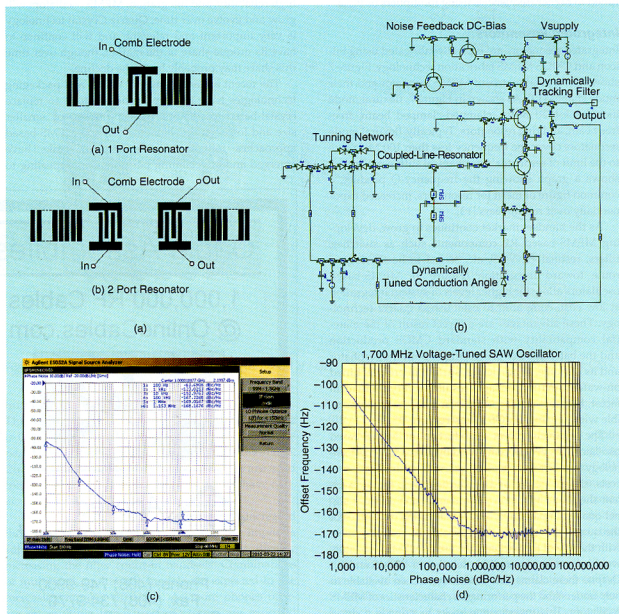

Figure 6. (a) SAW resonator, (b) typical schematic 1 GHz VCSO (patented), (c) measured phase noise plot of 1 GHz VCSO, and (d) measured phase noise plot of 1.7 GHz VCSO with latest technological advancements in tiny size (0.4 × 0.4 inches).

temperature stability about 50-ppm. As for the 10-ppm temperature stability, this is good, as MEMS oscillator had offered 25–50 ppm so far. It is not clear if there is a market for this specific temperature stability range. Most consumer and IT applications can work with 30 to 100 ppm, on the higher side, and TCXO for mobile phones and GPS require 0.5 to 2 ppm. A recent publication shows that the temperature-compensated MEMS oscillator (TCMO) shows 5 ppm over the temperature range from -40°C to $+85^{\circ}\text{C}$ with phase noise performance of -136 dBc/Hz at 1 kHz offset from the 13 MHz carrier, relating to phase noise of 123.9 MHz carrier is -116 dBc/Hz [5]. Although the technology offers a cost-effective solution, phase and frequency discontinuity deteriorates the jitter, resulting in sudden jumps in phase that plague commercially available fractional N-PLL-based design. We believe the small size and rugged reliability that MEMS oscillators can offer are an important part of the future of the frequency control market. The MEMS based oscillator addresses a strong need for high shock-resistant timing components in the precision guided munitions (PGM) markets.

Another new technology that is suitable as a cost-effective, integrable alternative for frequency-controlled circuits is the tunable active inductor oscillator (TAIO). The TAIO solution builds upon several decades of development that have created a mature silicon integrated circuit industry.









Flexural Mode	Bulk Mode	
Folded Beam		Disk (Contour Mode) 
Clamped-Clamped Beam		Disk (Wine Glass Mode) 
Free-Free Beam		Square (Extension) 
Ring		Square (Deform) 

Figure 7. A typical matrix of MEMS resonators and their mode shapes.

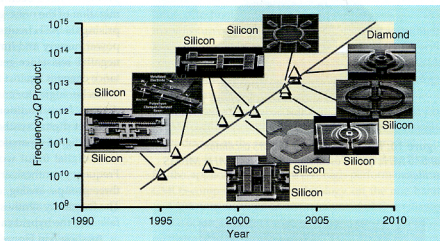

Figure 8. A typical plot showing exponential growth in the frequency-Q product of micromechanical resonators over time [2], [3].

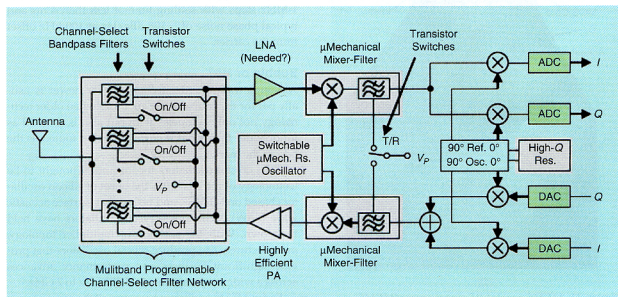

Figure 9. Typical RF MEMS replacing devices (Shaded) in TxRx section of handsets [6].

Last but not least, TAIO technologies, by virtue of their small size, are also extremely rugged and well-suited to low-jitter applications such as in military and aerospace equipment, where resistance to shock and vibration is at a premium. The tunable active inductor is becoming a reality for IC solutions that have been waiting for an improved dynamic range, phase noise performance, reliable, scalable and low-cost alternative to varactor diodes

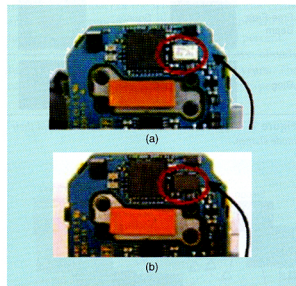

Figure 10. Typical quartz and MEMS oscillator. (a) 67.5 MHz quartz oscillator, and (b) 67.5 MHz MEMS oscillator.

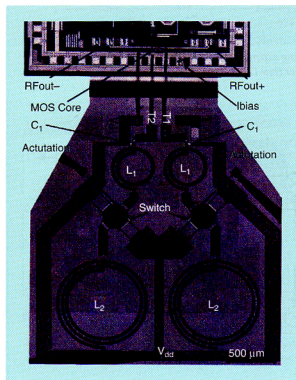

Figure 11. MEMS enabled RF signal source (MEMS-CMOS oscillator) [18].

as tunable capacitors. Exciting market possibilities exist for active tunable inductors in new product areas such as tunable oscillators, filters and resonators. This study will benefit the existing users of oscillators such as electronic circuit manufacturers of hand-held electronic consumer products (such as mobile phones and laptops), who seek to lower costs by replacing varactor-tuned oscillators with active inductor oscillators, which are positioned to become a preferred solution for many types of consumer and communication applications.

The typical active inductor is based on the gyrator (Figure 12), which can be realized by connecting an inverting amplifier to a noninverting one in parallel and back-to-back. Figure 13(a) and (b) show the typical schematic and impedance plot of the active inductor. Care must be taken to avoid encircling and crossing point 4.3 GHz (#3), which limits the applications [Figure 13(b)] [10]. Several approaches to overcome these problems have been considered, including the minimization of the noise generated by active devices comprising the ATI circuits. Even these techniques result in power hungry and limited band characteristics due to negative resistance generated in series with the inductance changes against the operating frequencies.

Technologies for creating frequency synthesizers are diverse, from traditional analog methods using PLLs to direct digital synthesizers (DDS) that rely on high-speed digital-to-analog converters (DACs) to transform digital input words into analog output signals. Frequency synthesizers can be categorized into mainly three groups: analog, digital or mixed signal (hybrid). The frequency synthesizer described in this Figure (10) falls into the hybrid category.

As shown in Figure 14, the block diagram for a typical synthesizer includes a VCO, phase-lock-loop (PLL) IC, charge pump, loop filter, amplifier, and voltage regulator. A typical unit tunes from 4000–8000 MHz in 1-MHz steps with settling time of less than 4 ms and typical phase noise of -108 dBc/Hz at 100 kHz offset from the carrier.

Bubble or Hit?

Although trading older technology for newer is usually par for the course, there are times when older technology not only competes with but also is as good as if not better than what is currently being touted as the best in the market.

Take crystal oscillators for instance. Thought to be technology of the past after the onset of silicon oscillators based on MEMS—and before that, surface acoustic wave (SAW) oscillators—crystal oscillators have held their own. With the addition of multiplier topology, manufacturers can produce crystal oscillators that provide significant business and performance advances across a wide frequency range of 750 kHz to 2 GHz.

So far, MEMS oscillators have met all the requirements with respect to phase noise, jitter, temperature stability,

power consumption, and reliability for the mainstream 1 to 125 MHz XO segment. This segment covers high-volume applications including consumer electronics, I/Os such as USB, computing, etc. The next application target for MEMS oscillators is to reach the accuracy requirements of TCXO for RF application. Three requirements are needed: (1) Temperature stability, (2) Low phase noise, and (3) Frequency accuracy. MEMS oscillators from different research groups may have reached individual specifications, but none has demonstrated meeting three of them at the same time. As a result, this is one of the first and probably the most important research goals for MEMS oscillators. With the development efforts among universities and industry, the MEMS oscillator is getting closer to RF applications. The good news is that due to the trend of reduced cost and size, RF system designers are tweaking system specifications to use low-cost (implying lower frequency accuracy) and integrated frequency reference sources. As MEMS oscillator researchers are trying to bring up the accuracy, system designers are bringing down the system requirements. We believe, in the near future, that these two specs will merge together.

Conclusion

The second and third generation of MEMS oscillators will target a larger market for compact oscillators in order to meet TCXO and OCXO performance requirements.

While silicon-based timing devices are still not as capable as crystal oscillators of undertaking sophisticated tasks, they are getting better, and will eventually replace crystals in many contexts. That will produce further synergies for the industry as mass production becomes cheaper

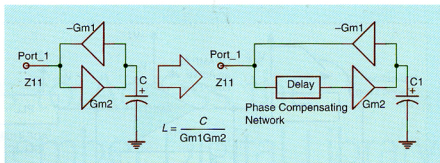

Figure 12. A typical representation of gyrator-based active.

and easier. These days, designers require higher frequencies and low jitter in oscillators, while buyers demand low cost and quick delivery. Timely oscillator options that can deliver the highest desired performance, while minimally compensating design steps are the key to cost-effective solutions. Fortunately, in the ongoing battle to push the limits of technology and lower component costs, oscillator manufacturers continue to close the gap between high-level performance and cost-effective purchasing, with conventional crystal technology paired with configurable oscillator technology. Like every exciting new technology targeting mass markets and driven by start-ups, confusion or exaggeration are present, but all in all, we believe that MEMS oscillators will follow the successful bulk acoustic wave devices as the second RF MEMS mass product.

There is a possibility that MEMS-based oscillators fill the application gap between high-performance non-CMOS-compatible quartz technology on the one hand, and low performance CMOS compatible LC oscillators on the other. The electrical performance of the best MEMS oscillators reported to date rivals the performance of typical quartz oscillators, while allowing for higher levels of system and package integration than what is possible with present day quartz technology [15]. It is concluded that, "the current steady, moderate growth in timing solutions

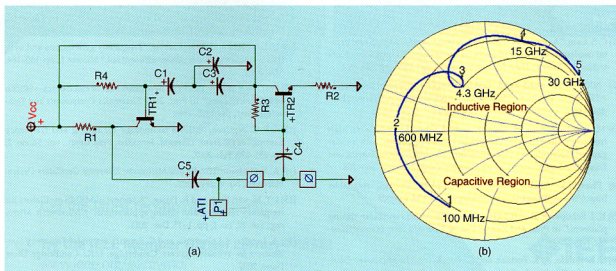

Figure 13. (a) A typical schematic of an active inductor, and (b) an impedance plot.

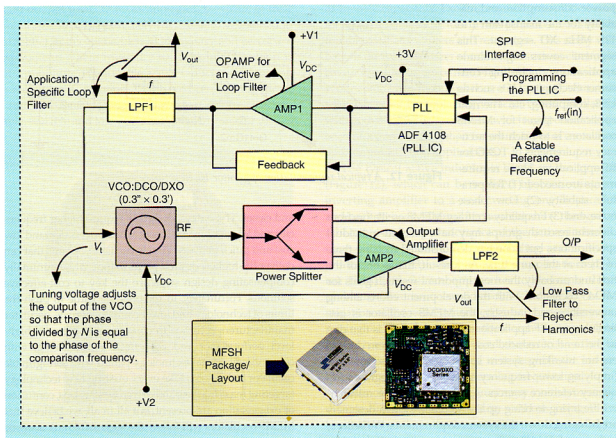

Figure 14. Block diagram of a configurable synthesizer using configurable TAIOS.

revenue is being driven by the expansion of strong consumer electronics and computer applications sectors, and because silicon timing solutions are improving. Silicon is increasingly able to handle some of the timing tasks traditionally given to crystals. However, continued underinvestment by telecoms infrastructure vendors could have a negative effect in the medium term." Overall, we expect the market for both nonsilicon and silicon resonator oscillators will share 50% down the road.

References

- [1] C. S. Lam, "A review of the recent development of MEMS and crystal oscillators and their impacts on the frequency control products industry," in *Proc. IEEE Int. Ultrasonics Symp.*, 2008, pp. 694-704.
- [2] NXP Aero quad-band GSM/GPRS/EDGE radio front-ends AERO42xx [Online]. Available: http://www.nxp.com/acrobat_download/literature/9397/75015986.pdf
- [3] M. Umeki, T. Sato, H. Uehara, and M. Okazaki, "622 MHz high frequency fundamental composite crystal resonator with an air-gapped electrode," in *Proc. IEEE Int. Ultrasonics, Ferroelectrics, and Frequency Control Joint 50th Anniversary Conf.*, 2004, pp. 365-368.
- [4] Phaselink. Analog frequency multiplier [Online]. Available: <http://www.phaselink.com/whitepaper/AFM-wp.pdf>
- [5] K. J. Schopel et al., "TCMTO: A versatile MEMS oscillator timing platform," in *Proc. 41st Annual Precise Time and Time Interval Meeting*, Nov. 2009.
- [6] U. L. Rohde, A. K. Poddar, and G. Boeck, *Modern Microwave Oscillators for Wireless Applications: Theory and Optimization*. Hoboken, NJ: Wiley, 2005.
- [7] U. L. Rohde and A. K. Poddar, "User-definable, low cost, low noise, and phase hit insensitive multi-octave-band tunable oscillator, phase hit and spectral pure tunable oscillator," U.S. Patent 7 605 670, Oct. 20, 2009.
- [8] R. Gaddi, A. Gnudi, E. Franchi, D. Guermandi, P. Tortori, B. Margesin, and F. Giacomozzi, "Reconfigurable MEMS-enabled LC-tank multi-band CMOS oscillator," in *Proc. IEEE MTT-S*, 2005.
- [9] C.T.-C. Nguyen, "RF MEMS in wireless architecture," in *Proc. Design Automation Conf.*, 2005, pp. 418-420.
- [10] U. L. Rohde and A. K. Poddar, "Tunable active inductor offers integrable and cost-effective alternatives of varactor-tuned VCOs," in *Proc. European Frequency and Time Forum and IEEE Int. Frequency Control Symp. (EFTF-IFCS)*, Besançon, France, Apr. 2009.
- [11] U. L. Rohde and A. K. Poddar, "Frequency generations and synthesis: Cost-effective & power-efficient sol.," *Microw. J.*, pp. 160-184, May 2009.
- [12] W.-T. Hsu and M. Pai, "The new heart beat of electronics—Silicon MEMS oscillators," in *Proc. 2007 Electronics Components and Technology Conf.*, pp. 1895-1899.
- [13] C.T.-C. Nguyen, "MEMS technology for timing and frequency control," *IEEE Trans. Ultrason. Ferroelect. Freq. Contr.*, vol. 54, no. 2, pp. 251-270, Feb. 2007.
- [14] A. V. Grebennikov, *RF and Microwave Transistor Oscillators Design*. Hoboken, NJ: Wiley, 2007.
- [15] J. T. M. van Beek and R. Puser, "A review of MEMS oscillators for frequency reference and timing applications," *J. Micromech. Microeng.*, vol. 22, no. 1, pp. 1-35, Dec. 2011.
- [16] A. Lacaíta, S. Levantino, and C. Samori, *Integrated Frequency Synthesizers for Wireless Systems*. Cambridge, U.K.: Cambridge Univ. Press, 2007.